

# 800AJ HC3

BOOM LIFT

ARTICULATING HI-CAPACITY BOOM LIFT



## HC3

**3 CAPACITY ZONES - EACH  
RATED FOR 3 OCCUPANTS +  
TOOLS/MATERIALS**

### KEY SPECS

**Platform Height**  
80-ft 4.4-in / 24.5-m

**Up and Over Height**  
32-ft 5.1-in / 9.9-m

**Horizontal Outreach**  
52-ft 3.8-in / 15.9-m

**Platform Capacity**  
750-lb/1000-lb / 340/454-kg - Restricted  
660-lb / 300-kg - Unrestricted

### KEY FEATURES

- Features three working zones for enhanced capacity; up to three workers and tools can fit onto the platform.
- Delivers a zero calibration automatic load sensing system that eliminates the need to use external weights to calibrate the machine.
- Utilizes an upgraded light panel that is more visible in the sun and a chassis tilt alarm that alerts the operator when the machine is on a slope that exceeds 5 degrees.
- Backed by industry-leading, customer-first service and support.

### ACCESSORIES & OPTIONS

- 1/2-in Air Line to Platform
- 43.5-lb Propane Tank
- AC Generator, 2500W or 4000W
- Accessory Packages:
  - SkyGlazier® Package
  - SkyPower® Package
  - SkyWelder® Package
- Arctic Package<sup>1</sup>
- Cold Weather Start Package<sup>2</sup>
- Hostile Environment Package
- Light Packages
- Platform Mesh to Mid or Top Rail
  - Aluminum or Plastic
- Platforms
  - Drop Bar, 30 x 36-in, 30 x 48-in, 30 x 72-in, 36 x 72-in, 36 x 96-in
  - Fall Arrest, Rear Entry, 36 x 72-in, 36 x 96-in
  - Inward Self-Closing Swing Gate, 30 x 48-in, 30 x 60-in, 36 x 72-in, 36 x 96-in
- Tri-Entry, Drop Bar or Swing Gate, 36 x 72-in, 36 x 96-in
- SkySense® Enhanced Detection System
- Soft Touch
- Tower Boom Stow Indicator
- Welder Ready Package

### STANDARD SPECIFICATIONS

#### Performance

Platform Height	80-ft 4.4-in / 24.5-m
Horizontal Outreach	52-ft 3.8-in / 15.9-m
Up and Over Height	32-ft 5.1-in / 9.9-m
Swing	360 Degrees Continuous
Platform Capacity - Restricted	750/1000-lb / 340/454-kg
Platform Capacity - Unrestricted	660-lb / 300-kg
Platform Rotator	180 Degrees Hydraulic
Jib Length	6-ft / 1.83-m
Jib Range of Articulation	130 Degrees (+70, -60)
Weight*	37,530-lb / 17,023-kg
Max. Ground Bearing Pressure	76 psi / 5.3 kg/cm <sup>2</sup>
Drive Speed	4.13 mph / 6.65 km/h
Gradeability	45%
Tilt Cut Out	4 Degrees
Turning Radius Inside	10-ft 2.9-in / 3.12-m
Turning Radius Outside	21-ft 6.2-in / 6.56-m

#### Engine

Dual Fuel – Ford MSG425-DF	84 hp / 62 kW
Diesel Fuel – Deutz TD2.9L4 Tier 4 Final	67 hp / 50 kW
Fuel Tank Capacity	39 gal / 147.6 L

#### Tires

Standard	Foam Filled, 18 x 625
Optional	Foam Filled Non-marking, 18 x 625

#### Hydraulic System

Capacity	40 gal / 151.4 L
Auxiliary Power	12V DC

### STANDARD FEATURES

- 4 Degree Tilt Alarm/Indicator Light
- 12V-DC Auxiliary Power
- 110V-AC Receptacle in the Platform
- All Motion Alarm
- Articulating Jib
- Center Storage Tray
- ClearSky Smart Fleet™ Hardware (CS550)
- Control ADE® System
- Engine Distress Shutdown – Selectable via Analyzer
- Engine Distress Warning
- Gull-Wing Hoods
- Hourmeter
- Hydrostatic Drive
- LED Motion/Amber Beacon (CS550)
- Lifting/Tie Down Lugs
- Load Sensing System
- Oscillating Axle
- Proportional Controls
- Platform Console Machine Status Light Panel\*\*
- Rapid Replaceable Platform with Self-Closing Gate
- Swing-Out Engine Tray
- SkyGuard SkyLine™
- USB-A and USB-C Charger

\*Certain Options or Country Standards Increase Weight.

\*\*Provides Indicator Lights at Platform Control Console for System Distress, Low Fuel, Degree Tilt Light and Foot Switch Status.

1. Includes Arctic Hydraulic Hoses (Drive And Steer Only) And Main Boom Cable, Extreme Cold Engine Oil, Fuel Conditioner, Engine Block Heater, Battery Blanket, Glow Plugs, Hydraulic Tank Heater, Oversized Foot Switch and Arctic Hydraulic Oil.  
2. Includes Battery Blanket, Hydraulic Tank Heater, Engine Block Heater Pad.

Not All Options Can Be Outfitted On the Same Machine; Consult Factory for Compatibility.  
Additional Accessories and Options Available Via JLG Aftermarket.

# 800AJ HC3

BOOM LIFT

ARTICULATING HI-CAPACITY BOOM LIFT



## DIMENSIONS

All dimensions are approximate

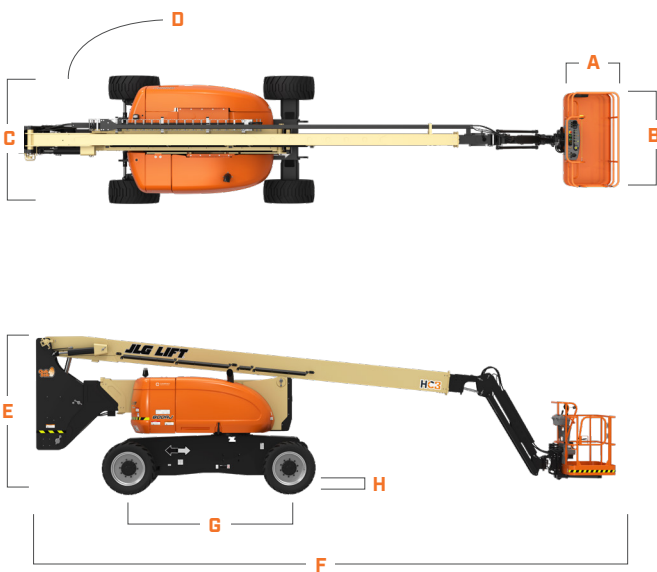

A.	Platform Width	36-in / 0.91-m
B.	Platform Length	96-in / 2.44-m
C.	Machine Width	8-ft 1.5-in / 2.48-m
D.	Tailswing	2-ft 5-in / 74-cm
E.	Machine Height	9-ft 9.1-in / 2.97-m
F.	Machine Length	36-ft 9.9-in / 11.22-m
G.	Wheelbase	10-ft / 3.05-m
H.	Ground Clearance	11-in / 28-cm

## REACH DIAGRAM

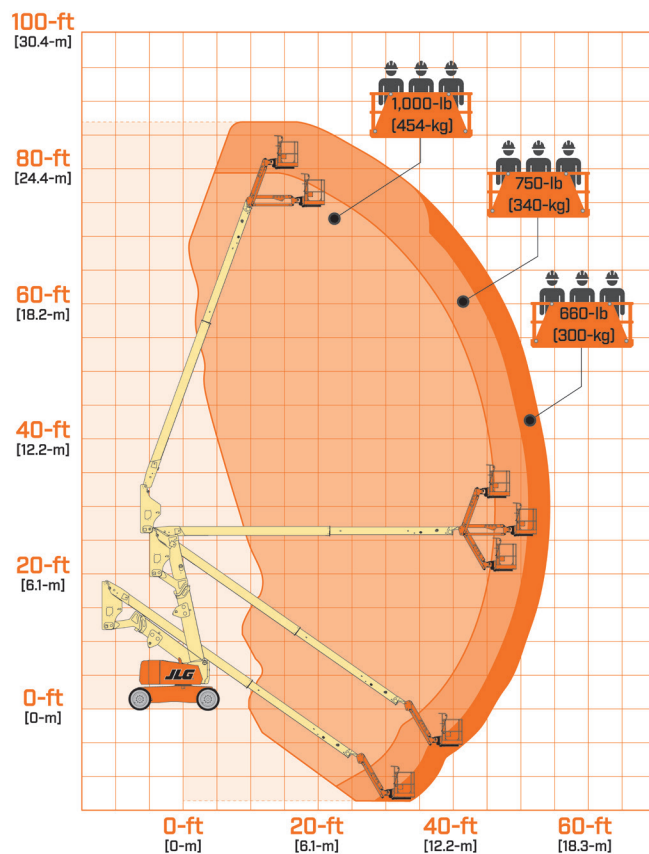

We provide coverage for one (1) full year, and cover all specified major structural components for five (5) years. Due to continuous product improvements, we reserve the right to make specification and/or equipment changes without prior notification. This machine meets or exceeds applicable ANSI and CSA requirements based on machine configuration as originally manufactured for intended applications. Please reference the serial number plate on the machine for additional information.



JLG INDUSTRIES, INC.  
Toll-free US 877-JLG-LIFT  
JLG.com

An Oshkosh Corporation Business